



TORKEL 840™ / 860™

Battery Load Units

Batteries in power plants and transformer substations must provide the equipment they serve with standby power in the event of a power failure. Unfortunately, however, the capacity of such batteries can drop significantly for a number of reasons before their calculated life expectancy is reached. This is why it is so important the check batteries at regular intervals, and the only reliable way of measuring battery capacity is to conduct a discharge test.

TORKEL 840-UTILITY™ is used for battery systems ranging from 12 to 250 V – often encountered in switch-gear and similar equipment. Discharging can take place at up to 110 A, and if higher current is needed, two or more TORKEL 840™ units or extra load units, TXL, can be linked together. Tests can be conducted at constant current, constant power, constant resistance or in accordance with a pre-selected load profile.

TORKEL 860-MULTI™ is designed primarily for people who travel from place to place to maintain battery systems having different voltages. It features excellent discharging capacity plus a broad voltage range and outstanding portability – a unique combination.

TORKEL 860™ is used for systems ranging from 12 to 480 V, and discharging can proceed at up to 110 A. If higher current is desired, two or more TORKEL 860™ units or extra load units, TXL, can be linked together. Discharging can take place at constant current, constant output, constant resistance or in accordance with a pre-selected load profile.

APPLICATION EXAMPLE

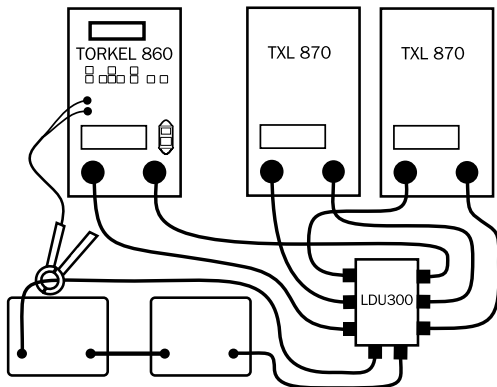

TOR KEL 860 and the extra loads TXL 870

Testing can be carried out without disconnecting the battery from the equipment it serves. Via a DC clamp-on ammeter, TOR KEL measures total battery current while regulating it at a constant level.

1. Connect TOR KEL to battery.
2. Set the current and start discharging. TOR KEL keeps the current constant at the preset level.
3. When the voltage drops to a level slightly above the final voltage, TOR KEL issues an alarm.
4. If the voltage drops low enough so that there is risk of deep-discharging the battery, TOR KEL shuts down the test. The total voltage curve and the readings taken at the end of the test are stored in TOR KEL. Later, using the TOR KEL Win program which runs on a PC under Windows®, you can transfer these readings to your computer for storage, printout or export. If your PC is connected to TOR KEL during the test, TOR KEL Win builds up a voltage curve on the screen in real time and displays the current, voltage and capacity readings. You can also control the test using TOR KEL Win.

SPECIFICATIONS

Load section

Maximum voltage:

TOR KEL 840: 290 V

TOR KEL 860: 480 V

Maximum current: 110 A

Maximum power: 15 kW

Load patterns: Constant current, constant power, constant resistance, current profile and power profile.

Current setting: 0-110.0 A (2999.9 A)¹⁾

Power setting: 0-15.00 kW (299.99 kW)¹⁾

Resistance setting: 0.1-2999.8 Ω

Battery voltage ranges:

TOR KEL 840: 4 ranges, selected automatically at start of test

TOR KEL 860: 5 ranges, selected automatically at start of test

Stabilization²⁾: ± (0.5% of reading + 0.5A)

¹⁾ Maximum value for a multi-unit system.

²⁾ For internal current measurement.

	Battery voltage	Highest permissible current	Resistor element
Range 1	10-27.6 V	110 A	0.165 Ω
Range 2	10-55.2 V	110 A	0.275 Ω
Range 3	10-144 V	110 A	0.55 Ω
Range 4	10-288 V	55 A	3.3 Ω
Range 5 (Tor kel 860)	10-480 V	55 A Power must not exceed 15 kW	3.3 Ω

Discharging capacity-examples

12 V battery (6 cells) ¹⁾		
Final voltage	Constant current	Constant power
1.80 V/cell (10.8 V)	0-52.0 A	0-0.56 kW
1.75 V/cell (10.5 V)	0-50.2 A	0-0.52 kW
1.67 V/cell (10.0 V)	0-47.2 A	0-0.47 kW

24 V battery (12 cells) ¹⁾		
Final voltage	Constant current	Constant power
1.80 V/cell (21.6 V)	0-110 A	0-2.37 kW
1.75 V/cell (21.0 V)	0-110 A	0-2.31 kW
1.60 V/cell (19.2 V)	0-101 A	0-1.95 kW

48 V battery (24 cells) ¹⁾		
Final voltage	Constant current	Constant power
1.80 V/cell (43.2 V)	0-110 A	0-4.75 kW
1.75 V/cell (42.0 V)	0-110 A	0-4.62 kW
1.60 V/cell (38.4 V)	0-110 A	0-4.22 kW

110 V battery (54 cells) ¹⁾		
Final voltage	Constant current	Constant power
1.80 V/cell (97.2 V)	0-110 A	0-10.7 kW
1.75 V/cell (94.5 V)	0-110 A	0-10.4 kW
1.60 V/cell (86.4 V)	0-110 A	0-9.5 kW

120 V battery (60 cells) ¹⁾		
Final voltage	Constant current	Constant power
1.80 V/cell (108 V)	0-110 A	0-11.9 kW
1.75 V/cell (105 V)	0-110 A	0-11.5 kW
1.60 V/cell (96 V)	0-110 A	0-10.5 kW

220 V battery (108 cells) ¹⁾		
Final voltage	Constant current	Constant power
1.80 V/cell (194 V)	0-55 A	0-10.7 kW
1.75 V/cell (189 V)	0-55 A	0-10.4 kW
1.60 V/cell (173 V)	0-51.7 A	0-8.94 kW

240 V battery (120 cells) ¹⁾		
Final voltage	Constant current	Constant power
1.80 V/cell (216 V)	0-55 A	0-11.9 kW
1.75 V/cell (210 V)	0-55 A	0-11.5 kW
1.60 V/cell (192 V)	0-55 A	0-10.5 kW

UPS battery (180 cells) ¹⁾ (TOR KEL 860)		
Final voltage	Constant current	Constant power
1.70 V/cell (306 V)	0-38 A	0-15 kW
1.60 V/cell (288 V)	0-38 A	0-15 kW

UPS battery (204 cells) ¹⁾ (TOR KEL 860)		
Final voltage	Constant current	Constant power
1.80 V/cell (367 V)	0-34 A	0-15 kW
1.60 V/cell (326 V)	0-34 A	0-15 kW

¹⁾ 2.15 V per cell when test starts



Measurement section

Current measurement: Display: 0.0-2999 A. Basic accuracy: \pm (0.5% of reading + 0.2 A). Resolution: 0.1 A.

Internal current measurement: 0-120 A.

Input for clamp-on ammeter: 0-1 V.

mV/A ratio: Software-settable

Input impedance: >1 M Ω .

Voltage measurement: Range is set automatically at start of test
0-60 V: Basic accuracy \pm (0.5% of reading + 0.1 V).
Resolution: 0.01 V.

0-500 V: Basic accuracy \pm (0.5% of reading + 1 V).

Resolution: 0.02 V.

Separate test cables can be connected for measurements taken at battery terminals.

Time measurement: Basic accuracy \pm 0.1% of displayed reading \pm 1 digit.

Other

Application field: The instrument is intended for use in high-voltage substations and industrial environments.

Memories available for settings: 9

Start/stop via external contact closure: Yes

Cable set: 2 x 3 m / 25 mm², 110 A with clamp/cable-lug.

Max 480 V. Weight: 3.0 kg.

Protection: Thermal cut-outs and automatic overload protection

Mains voltage: 100-240 V \pm 10%, 50-60 Hz, or 95-300 V DC

Dimensions instrument: 210 x 353 x 700 mm
(8.3" x 13.9" x 27.6")

Dimensions, transport case: 265 x 460 x 750 mm
(10.4" x 18.1" x 29.5")

Weight: 20.5 kg (45.2 lbs), 29 kg (64 lbs) including transport case

Warranty: 1 year

The above specifications are valid at nominal input voltage and an ambient temperature of +25° (+77°F).

Specifications are subject to change without notice.

EXTRA ACCESSORIES

TORKELWin software

TORKELWin for TORKEL 820/840/860

Art. No: BS-8208X

TORKELWin for TORKEL 720

Art. No: BS-8207X

Extra Loads TXL850 and TXL870

These resistive extra loads do not perform any regulating functions. They are designed for use together with TORKEL Battery Load Units. Their purpose is to provide higher load currents for use in constant current or constant power tests. Together, TORKEL and the TXL Extra Loads form a system that can discharge batteries with currents of up to several kA.

TXL850 is intended for 48 V systems. The resistor packages in these units are divided into three parts, and the user determines how many are to be connected. TXL Extra Loads are connected directly to the battery, and TORKEL measures the total current using a clamp-on ammeter.

TXL870 is intended primarily for 125 and 240 V battery systems. Here, the resistor package is divided into two parts. At 125 V, you can choose between connecting one or both of them. At 250 V, both are connected in series.

TXL Extra Loads are shut down automatically when TORKEL is stopped.

Extra Load TXL850

Used when higher current is desired for batteries of up to 48 V. Here, a DC clamp-on ammeter must be used to enable TORKEL to measure the total current.

Specifications TXL850

Maximum current:	300 A
Maximum voltage:	56 V
Maximum power:	16.4 kW

Internal resistance

Manual 3-position selector

Position 1

Internal resistance:	0.55 Ω
Current at 55.2 V (24 x 2.3 V):	100 A
Current at 43.2 V (24 x 1.8 V):	78.5 A

Position 2

Internal resistance:	0.275 Ω
Current at 55.2 V (24 x 2.3 V):	200 A
Current at 43.2 V (24 x 1.8 V):	157 A

Position 3

Internal resistance:	0.184 Ω
Current at 55.2 V (24 x 2.3 V):	300 A
Current at 43.2 V (24 x 1.8 V):	235 A



Extra Load TXL870

Used when higher current is desired, primarily for 110-250 V battery systems. Here, a DC clamp-on ammeter must be used to enable TOR KEL to measure the total current.

Specifications TXL870

Maximum power: 15.8 kW

Set for maximum of 140 V:

Maximum current: 112 A

Internal resistance: 1.24 Ω or 2.48 Ω (manually selectable)

Discharging capacity-examples

	2.3 V/cell	1.8 V/cell
24 V battery	22.2 A	17.4 A
48 V battery	44.4 A	34.8 A
110 V battery	100.0 A	78.4 A

Set for maximum of 280 V:

Maximum current: 56 A

Internal resistance: 4.95 Ω

Discharging capacity-examples

	2.3 V/cell	1.8 V/cell
220 V battery	50.1 A	39.2

TOR KEL/TXL systems-examples

Systems containing TOR KEL 840/860 and TXL830 units

24 V battery (12 cells), Discharge from 2.15 to 1.8 V/cell

Maximum constant current (A)	Number of units TOR KEL 840/860	Number of units TXL830
265	1	1
452	2	1
684	2	2
916	2	3
1026	3	3
1258	3	4
1490	3	5

Systems containing TOR KEL 840/860 and TXL850 units

48 V battery (24 cells), Discharge from 2.15 to 1.8 V/cell

Maximum constant current (A)	Number of units TOR KEL 840/860	Number of units TXL850
266	1	1
453	2	1
687	2	2
921	2	3
1032	3	3
1266	3	4
1500	3	5

Systems containing TOR KEL 840/860 and TXL870 units

110 V battery (54 cells), Discharge from 2.15 to 1.8 V/cell

Maximum constant current (A)	Number of units TOR KEL 840/860	Number of units TXL870
188	1	1
266	1	2
344	1	3
422	1	4
532	2	4
610	2	5
688	2	6
766	2	7
845	2	8
923	2	9
1001	2	10

Systems containing TOR KEL 840/860 and TXL870 units

120 V battery (60 cells), Discharge from 2.15 to 1.75 V/cell

Maximum constant current (A)	Number of units TOR KEL 840/860	Number of units TXL870
194	1	1
279	1	2
363	1	3
473	2	3
557	2	4
642	2	5
726	2	6
810	2	7
895	2	8
979	2	9

Systems containing TOR KEL 840/860 and TXL870 units

220 V battery (108 cells), Discharge from 2.15 to 1.8 V/cell

Maximum constant current (A)	Number of units TOR KEL 840/860	Number of units TXL870
94	1	1
133	1	2
188	2	2
227	2	3
266	2	4
306	2	5
345	2	6
384	2	7
423	2	8
463	2	9



Other

Application field: The instrument is intended for use in high-voltage substations and industrial environments.

Protection: Thermal cut-outs and automatic overload protection

Mains voltage: 100-240 V \pm 10%, 50-60 Hz or 95-300 V DC

Dimensions, instrument: 210 x 353 x 600 mm
(8.3" x 13.8" x 23.6")

Dimensions, transport case: 265 x 460 x 750 mm
(10.2" x 18.1" x 29.5")

Weight: 13 kg (28.7 lbs)

21.4 kg (47.2 lbs) including transport case.

Cable set for TXL850: 2 x 3 m, 70 mm², 270 A with cable lug.
Max 100 V. Weight: 5.0 kg

Cable set for TXL870: 2 x 3 m, 25 mm², 110 A with
clamp/cable-lug. Max 480 V. Weight: 3.0 kg

The above specifications are valid at nominal input voltage
and an ambient temperature of +25° (+77°F).

Specifications are subject to change without notice.

Load Distribution Unit, LDU300, complete with cable set

Used to connect three TOR KEL/TXL systems to the battery via only
one cable for each terminal. Total current must not exceed 270 A.
This junction box also has three outlets for supplying power from
the battery (95-300 V) directly to the battery load units.

Dimensions junction box: 200 x 306 x 75 mm (7.9" x 12" x 3")

Weight: 2.5 kg (5.5 lbs)

Cable set: 2 x 1.5 m, 70 mm² cable for connecting junction box
to battery. Connection: Cable lug. 6 x 3 m, 25 mm² cable for
connecting three battery load units to the junction box.

Weight: 11.5 kg (25.4 lbs)

Art. No: BS-90050

DC clamp-on ammeter, 200 A

Can be used to measure current in a circuit outside TOR KEL.

Art. No: XA-12792

DC clamp-on ammeter, 1000 A

Can be used to measure current in a circuit outside TOR KEL.

Art. No: XA-12790

Extension cable set, 110 A

2 x 3 m, 25 mm². Max 480 V.

Weight: 3.0 kg

Art. No: GA-00552

Cable set for measuring voltage at battery terminals

Length: 2 x 5 m.

Art. No: GA-00210

ORDERING INFORMATION

TOR KEL 840-Utility Battery Load Unit

Complete with cable set GA-00550 and transport case GD-00054.

Mains voltage: 100-240 V \pm 10%

Art. No: BS-49094

TOR KEL 860-Multi Battery Load Unit

Complete with cable set GA-00550 and transport case GD-00054.

Mains voltage: 100-240 V \pm 10%

Art. No: BS-49096

TXL850 Extra Load

Complete with cable set GA-00554 and transport case GD-00054.

Mains voltage: 100-240 V \pm 10%

Art. No: BS-59095

TXL870 Extra Load

Complete with cable set GA-00550 and transport case GD-00054.

Mains voltage: 100-240 V \pm 10%

Art. No: BS-59097

TOR KEL Win Software

TOR KEL Win for TOR KEL 820/840/860.

Art. No: BS-8208X

TOR KEL Win for TOR KEL 720.

Art. No: BS-8207X

DENVER
metrología electrónica, S.L.

Tel: +34 91 569 8006

info@denver.es - www.denver.es



INLEC™
TEST EQUIPMENT

HIRE THIS PRODUCT NOW

WWW.INLEC.COM

FREEPHONE 0800 052 1110

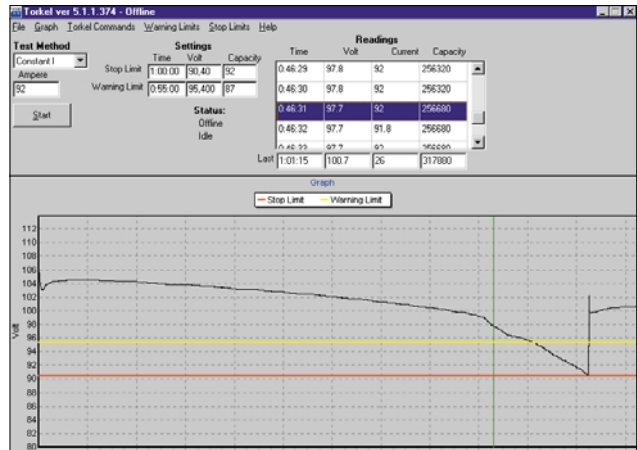

TORKEL Win showing total voltage curve



Cable set GA-00550

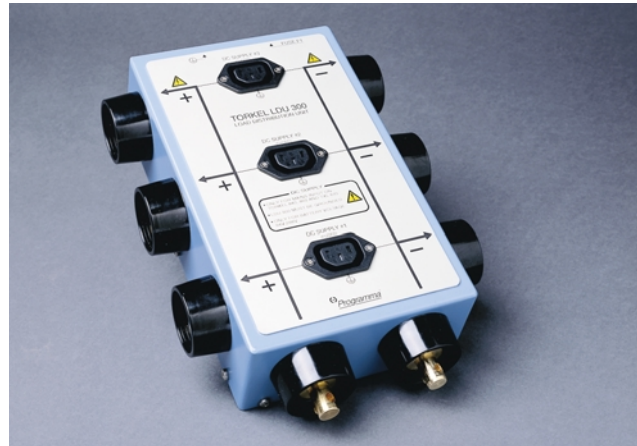

LDU300

